

The Phoenix Patio Heater by DCS

No.:

Standard Features

- Efficient 40,000 BTU burner system with 100% safety shut-off, piezo electric ignition and adjustable heat control knob.
- Professional performance. Up to 20 ft. circle of heat.
- American Gas Association and Canadian Gas Association Certified.
- Weighted base houses a 20 lb, LP/ Propane tank which will last approximately 10 hours with heater on "High".
- For indoor or outdoor operation.
- No electricity required.

Optional Features

- The only heater with all stainless steel construction.
- Available colors for Phoenix Patio Heater:
 - White
 - Black
 - Cobalt Blue
 - Hunter Green

Optional Features

- When ordering please specify:
 - Type of gas - Natural or Propane.



Item #

The Phoenix Patio Heater by Dynamic Cooking Systems is created to convert cold, unusable areas into warm and comfortable places for any activity. Functional and novel, The Phoenix becomes a meeting place when entertaining guests. It can complement the warmth of any spa or heated pool during evening swims. For restaurants it is the most cost efficient way to expand seating capacity when the weather turns cool while at the same time, offering a unique accent to your customers dining experience. Hard at work, The Phoenix will provide warmth to those of us needing to get the job done regardless of chilling temperatures. The only patio heater fashioned from polished stainless steel, The Phoenix will be lasting and reliable. We're so sure of ourselves that every Phoenix Patio Heater is covered by one year warranty. Who said that the summers can't be endless?



Specifications

Standard Models

- DCS PH1 Freestanding Model
- DCS PH2 Build In Model

Gas Requirements

- The Phoenix Patio Heater is available in either Freestanding or Build in configurations for use with Natural or LP/ Propane gases.

Clearances

Sides	Rear	Ceiling
24"	27"	19"

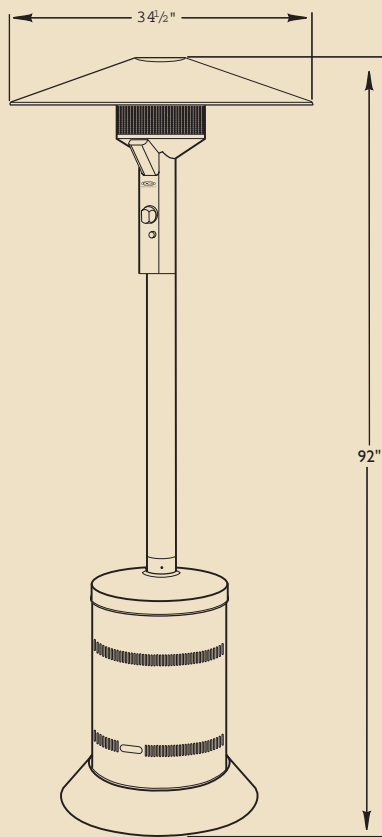

DCS PH1 Freestanding Model

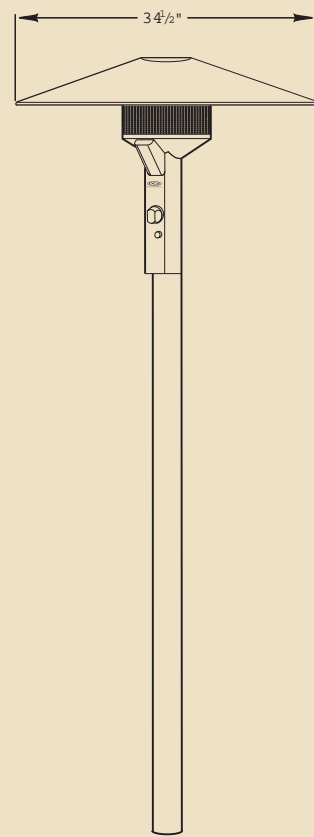

DCS PH2 Build In Model

Shipping Dimensions/Weight

36" length x 24" wide x 37" high

- Unit Weight/ Shipping Weight
DCS PH1-FS = 105 lbs
DCS PH2-BI = 60 lbs

Warranty

All DCS Phoenix Patio Heaters are covered by a one year parts and labor warranty excluding igniter. Five year (5) limited warranty (stainless steel components only). A detailed warranty is included with the appliance or is available upon request.

Dynamic Cooking Systems is a quality manufacturer of commercial cooking equipment, professional outdoor grills and hot plates, outdoor heating equipment, and professional cooking equipment for home use.



Because of continuing product improvement these specifications are subject to change without notice.



©1998 Dynamic Cooking Systems, Inc.
5800 Skylab Road, Huntington Beach,
CA 92647. For more information, visit
our web site at www.dcs-range.com or
ask your dealer.
Tel.: 800-433-8466 714-372-7000
Fax: 714-372-7001

Made in USA P/N 17256 3/99